

10. Connect the airgap drain outlet to the garbage disposal drain inlet by using a length of 7/8" dishwasher drain line hose and two non-rust hose clamps. The ET200 model airgap may also be discharged into a 1 1/2" x 3/4" branch tailpiece in the absence of a garbage disposal. (See Fig. 5) For best results, clean out the inside of the disposal nipple by reaming with a screwdriver. Install the drain hose as short and direct as possible with no kinks or sags and ensure that the disposal or branch tailpiece drain inlet connection is low enough to accommodate the gravity fed airgap drain.

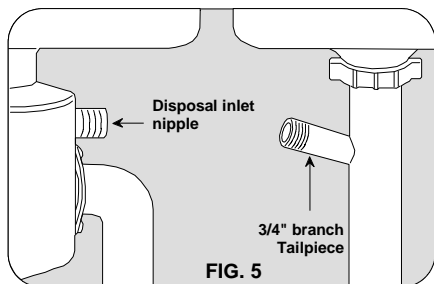

**IMPORTANT:**

Remove the knock-out plug when the disposal inlet nipple is not already in use. Knock out the plug inside the disposal nipple by using a hammer and flat screwdriver. Tap away all edges of the knock-out plug until only a round hole remains. Remove all pieces of plug left inside disposal after ensuring that power has been disconnected. Run fingers carefully around bottom circumference of the chamber to search for any hidden fragments.

(See Caution below)

**CAUTION:** The installer is urged to exercise extreme caution whenever reaching hand inside the disposal. After confirming that power has absolutely been turned off (and will stay off until job is done), use extra care that fingers are not cut on any sharp surfaces.

**REPLACEMENT INSTALLATION**

(To replace an existing dishwasher airgap with the ET200 model)

1. Remove both inlet and outlet drain hoses from existing dishwasher airgap and save the hose clamps for reassembly.
2. Remove the existing airgap from the sink or countertop and prepare a clean surface for the installation of the new ET200 model.
3. Follow instructions 2 through 10 above.

**MAINTENANCE:**

Dishwasher airgaps may become clogged with leftover food debris escaping the dishwasher filtering mechanism. The ET200 model was designed to be easily cleaned in the event of a clog. To clear a blockage which has become logged in the inner cap spillway, pull off the cover cap and unscrew the top cap nut. Remove the inner cap by sliding it straight up to remove any trapped food particles. Then carefully replace the inner cap the same way it was removed, taking care to align the vertical spline on the cap to the channel in the airgap chamber.

Serving the Water Treatment & Plumbing Industry

MADE IN USA



Make sure the custom O-ring is still properly seated in its original position, and re-secure the top cap nut before replacing the cover cap.



Copyright 2019 AIR GAP INTERNATIONAL



Model: **ET200 Series**  
**( DLA-TAG™ )**

MADE IN USA

*Twin Air Gap*

**DRAIN LINE ADAPTER**

- Combination Dishwasher Airgap For Reserve Osmosis and Water Softener Appliances

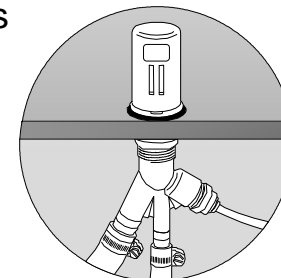

Part No.









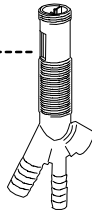

ET200-001	TAG-25QC	Chrome Cover Cap ,1/2"MIPTX1/4"quick connect
ET200-002	TAG-58BI	Chrome Cover Cap ,1/2"MIPTX 5/8" barb adapter
ET200-004	TAG-NCNF	No cap /no fitting
ET200-006	AG-CH	Polished Chrome Brass Cover Cap, 1/2" MIPTX 5/8" barb adapter,1/2" MIPT X 1/4" quick connect, 1/2" MIPT white PVC Schedule-40 plug
ET200-007	AG-SN	Satin Nickel Finish Brass Cap, 1/2"MIPTX 5/8" barb adapter,1/2" MIPT X 1/4" quick connect,1/2" MIPT white PVC Schedule-40 plug
ET200-009	AG-PNVD	Polished Nickel Finish Brass Cap, 1/2"MIPTX 5/8" barb adapter,1/2" MIPT X 1/4" quick connect, 1/2" MIPT white PVC Schedule-40 plug
ET200-010		Matt Black Finish Brass Cap, 1/2"MIPTX 5/8" barb adapter,1/2" MIPT X 1/4" quick connect, 1/2" MIPT white PVC Schedule-40 plug
ET200-011	AG-ORB	Oil Rubbed Bronze Finish Brass Cap, 1/2"MIPTX 5/8" barb adapter,1/2" MIPT X 1/4" quick connect,1/2" MIPT white PVC Schedule-40 plug

# ET200 SERIES

## Installation Procedures

For Combination Dishwasher Twin Air Gap

### LIST OF PARTS ENCLOSED

1 – Twin Air Gap <u>Main Body</u> .....		1 – Cap Compression <u>Top Nut</u> .....	
1 – Twin Air Gap <u>Cover Cap</u> .....		1 – Deck Mount <u>Middle Nut</u> .....	
1 – Twin Air Gap <u>Inner Cap</u> .....		1 – Under-counter <u>Bottom Nut</u> .....	
1 – Inner Cap Seal <u>O-Ring</u> .....		1 – Deck Mount <u>Gasket Seal</u> .....	
Optional (see model numbers table with Description on first page)			
1 – 1/2" Male Thread X 1/4" Push-In Quick connect or 5/8" Barb Adapter, 1/2" MIPT white PVC			
Schedule-40 plug			

- **The ET200 Series provides a multipurpose twin inlet airgap for the installation of a reverse osmosis, water softener or dual drain dishwasher appliance.**
- **Replacing an existing dishwasher airgap with ET200 model allows the installer to use a non-airgap faucet.**

Please read the instructions once through before starting.

### NEW INSTALLATION

1. Determine a suitable location to make a 1 1/2" hole in the sink or countertop if one is not already available. The type of tool used to make the hole will depend on the sink or countertop material. For stainless steel sinks or custom countertop materials, use a 1 1/2" chasse punch. For enameled cast iron sinks or custom counter top materials, use a Relton drill set. Follow the cutting tool manufacturer's recommended instructions carefully, or have the hole cut by a professional.

2. Pull off the TAG cover cap and unscrew the top nut leaving the inner cap and O-Ring in place. Screw the bottom nut further down the body of the air gap to leave sufficient length for the airgap to protrude up through the 1 1/2" hole from underneath. (See Exploded View Fig. 1)

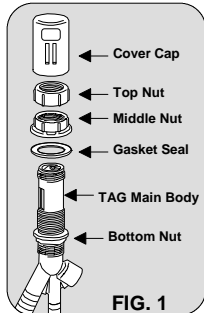

3. Insert the airgap up through the hole from under the sink and install the gasket seal and middle nut. Screw the middle nut down until the Top of the nut meets the Bottom of the airgap window on the main body. DO NOT tighten or secure the airgap to the sink with the middle nut. (See Fig. 2a)

4. Orient the bottom of the airgap inlets and outlet under the sink as desired. Then install the airgap to the sink by pulling down on the airgap while tightening the bottom nut clockwise. (See Figs. 2a & b) Secure the airgap firmly to the sink so that it will not rotate but DO NOT OVER-TIGHTEN.

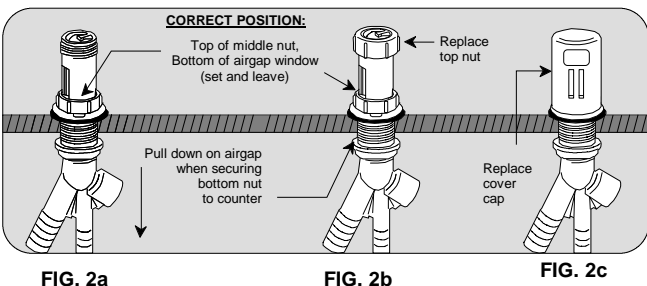

5. Replace the top nut on the main body (over the inner cap and O-ring) tight enough to prevent any leaks during the operation of the airgap. (See Fig. 2b) Then replace the cover cap until it seats fully onto the middle nut. Rotate the cover cap so that the two airgap ports face the sink. (See Fig. 2c)

6. Connect the dishwasher drain hose to the 5/8" middle inlet barb at the bottom of the airgap with a non-rust hose clamp. (See Fig 3a)

NOTE: the ET200 model comes with either a threaded push in fitting adapter for RO drains or a barbed insert fitting got 2-drawer dishwashers and softener drains.

7. Connect the RO drain push-in adapter by applying Teflon tape to the 1/2" male thread before screwing the adapter into the threaded 1/2" female inlet. DO NOT OVER-TIGHTEN. (See Fig. 3b)

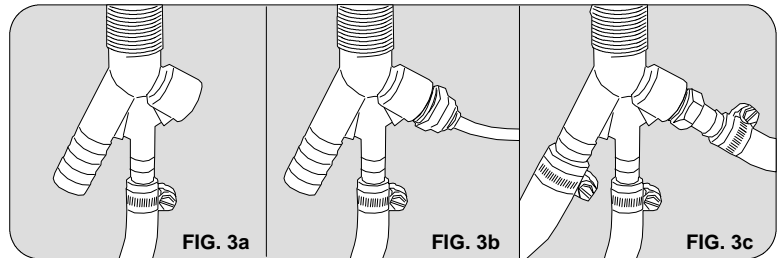

8. Connect the RO drain tube to the push-in adapter: Tubing must seat fully past O-ring into the bottom of the socket. Verify tube surface is free of scratches and tube end has a square cut. The tube may be removed by depressing the push-in collet evenly against the adapter, then pulling the tube out in the opposite direction at the same time. (See Fig. 4)

9. Dual Dishwasher & Water Softener drain lines may be connected to the 1/2" threaded female inlet by using an appropriately sized barb or push-in adapter. (See Fig. 3c)

FIG. 4 Speed Fit / Push-in Connector

