

10. Connect the air gap outlet to the garbage disposal drain inlet by using a length of 7/8" dishwasher drain line hose and two hose clamps.

**IMPORTANT:**

Disconnect disposal power and remove the disposal knock-out plug if still present. Knock out the plug inside the disposal nipple using a hammer and flat blade screwdriver.

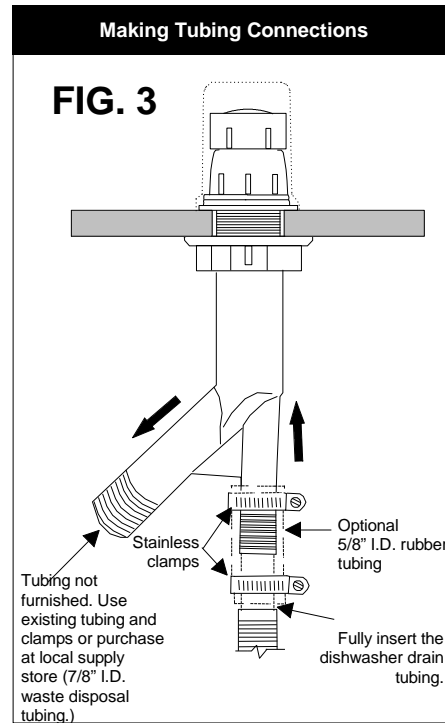

**Model:**

# AG200-003

**AMERIGAP 52**

## HIGH QUALITY DISHWASHER AIR GAP

**MAINTENANCE:**

Dishwasher air gap may become clogged with food debris. The AG200-003 is designed to be easily cleaned in the event of a clog.

To clear a blockage, pull off the Cover cap and unscrew the Top Housing. Remove any trapped food particles. After cleaning replace the Top Housing the same way it was removed. Install the Cover cap.

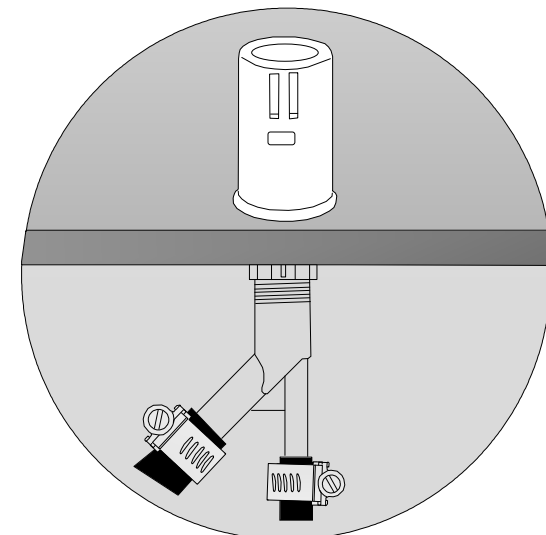

# AG200-003

## Installation Procedures

### LIST OF PARTS ENCLOSED

1 – Main Body

1 – Cover Cap

1 – Bottom Nut

1 – Mounting Washer

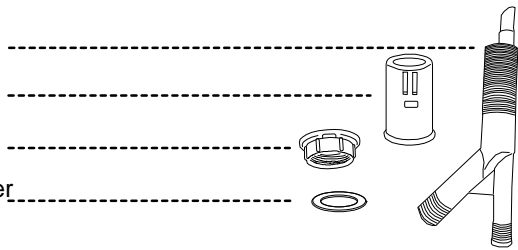

1 – Top Housing

1 – Top Nut



- Easy to clean and maintain
- Easy cleaning when needed
- Extra-long threads for mounting through thick countertops
- A robust mounting nut that will not strip

### NEW INSTALLATION

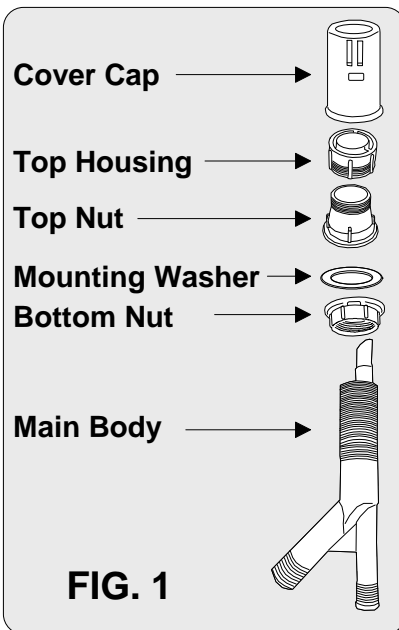

1. Unit installation requires a 1-3/8 inch hole in the sink or countertop.
2. Unscrew the top housing. Next, unscrew and remove the top nut and the mounting washer. Screw the bottom nut further down the body of the air gap; leave sufficient length for the air gap to protrude up through the mounting hole.
3. Insert the air gap up through the hole in the sink and reinstall the mounting washer and top nut over the threaded Main body of the unit.
4. Install top housing and screw it down fully, hand tight only.
5. Orient the bottom inlet and outlet under the sink as desired. Then, pull down on the air gap while tightening the Bottom nut clockwise.

DO NOT OVER TIGHTEN.

Do not clean decorative housing with any abrasive cleaner as it will void the warranty. To clean the air gap, use only soap and water.

#### CAUTION:

NO TOOLS  
Use hands only above the sink

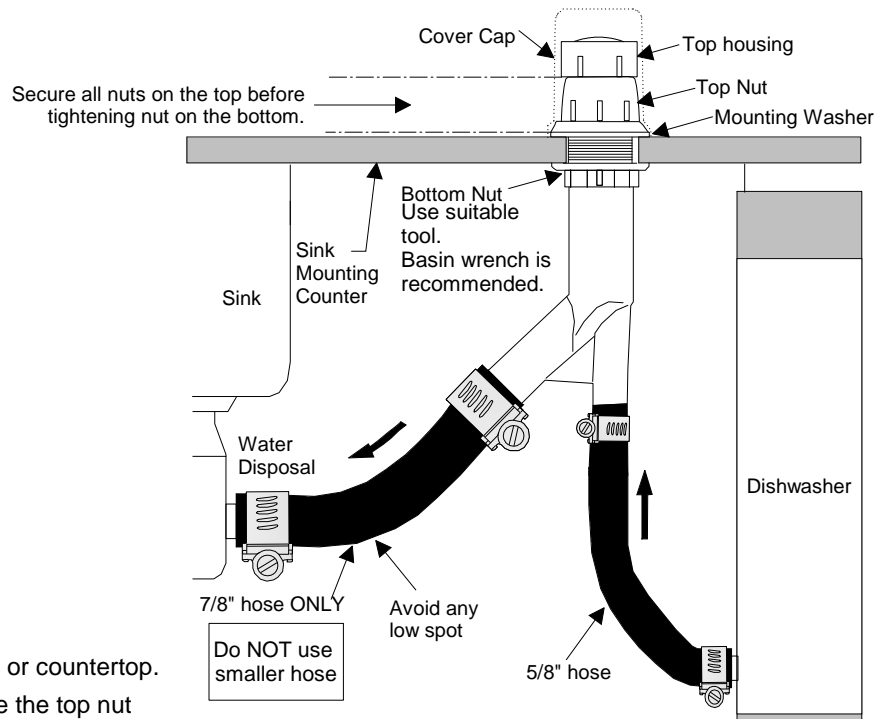

6. Install the Cover cap over the housing. Rotate the Cover cap so that the two air gap openings face the sink.
7. Connect the dishwasher drain hose to the 5/8" inlet port with hose clamp.
8. Connect the air gap drain hose to the 7/8" outlet port with hose clamp.
9. For making tubing connection from dishwasher, connect 3" length 5/8" hose, to the inlet ports using clamps. Clamp the other end to the tubing from the dishwasher. (See Fig.3)