

GAP-A-FLO GENERAL INSTALLATION GUIDELINES

Note: the most important things to remember about "Air Gap" when installing these "Air Gap" units are:

- (a) The units are open to atmosphere thus unlike most plumbing fittings or backflow devices; these units cannot be pressurized.
- (b) We presume that upstream piping has sufficient internal pressure to deliver water to the inlet port. The upstream piping can vary as to size and length and this piping generally has very little effect on the performance of these units. Softener manufacturer usually specifies 1/2" I.D. piping.
- (c) The unit is a gravity flow device. Thus they need to be installed per the manufacturer's instructions and permanently clamed or affixed into the "down" leg of drain line piping, such that the stream of water whether forced by upstream pressure, or by gravity only, will flow freely past the "Air Gap" then continue flowing freely through the attached downstream piping.
- (d) For proper unit operation, downstream piping should present a minimum of resistance or back pressure to the flowing stream of water and this piping must not be smaller than upstream piping. Unit max. flow rates can vary widely. They depend primarily on each unique piping installation.

Specific Installation Instructions

(Always comply with local plumbing codes during installation). If needed, order form #211220 or #2110113 respectively for more installation instructions or technical data.

1. Compression coupling (#211213) is recommended. It adapts 5/8" O.D. piping (polyflex, quest or rigid copper) to the inlet port of our Gap-a-flo unit. (Also, inlet port is 1/2" MIP and 1/4" FIP threads; outlet port is 3/4" MIP and 3/8" FIP threads)
2. Gap-a-flo unit (P/N 211211) includes outlet port compression coupling for 5/8" O.D. polyflex or quest piping. If you prefer, you may discard this bottom compression nut and pipe directly to the bottom threaded port.
3. This unit provides only an "AIRGAP" and not a "Trap". If no trap exists downstream of the outlet piping termination then you will need to fabricate a trap downstream of this unit. Downstream piping should make an indirect and not a direct hard connection to the house drain/waste piping. (Ref. 7 below).
4. For all automatic softeners, filters and other large flow situations: never use the small black "floe centering" washer and never use the female threads on the Gap-a-flo unit. The smaller internal threads are intended for many "RO" equipment installations with flows less than (1gmp).
5. Install unit close as possible to the drain termination point. Keep the outlet (downstream) piping as large and as short as possible and try to avoid elbow fittings. For (P/N 211211), even with an idea installation; suggest max. flow rate of (6 to 7 GMP).
6. You can install the same size 5/8" O.D. polyflex piping at inlet and outlet of the unit or you can use larger piping at the outlet. Never install smaller piping at the outlet. Units (P/N 211212) are available with larger internal bore at the outlet port. Connection to outlet port then is via the 3/4" MIP thread. (P/N 211212) units; suggested max. flow rate about (7 to 8 GPM)*.
7. Inlet port and "critical level" (C/L) are marked on each unit. Install unit with inlet port elevated above outlet port. Unit can be oriented anyway between 45° and vertical. Install and clamp piping and unit so the "C/L" is elevated one inch or more above the flood level of: the sink, sump, floor drain, floor grate or standpipe where the downstream piping is terminated.

Inlet port and "critical level" (C/L) are marked on each unit. Install unit with inlet port elevated above outlet port. Unit can be oriented anyway between 45° and vertical. Install and clamp piping and unit so the "C/L" is elevated one inch or more above the flood level of: the sink, sump, floor drain, floor grate or standpipe where the downstream piping is terminated.

8. Always cycle the installed equipment a couple of times thru the full cycle before leaving to be sure of no leaks and proper "Air Gap" performance. *For large flows use (2) units in parallel or fabricate an Air Gap with larger pipe.
8. Always cycle the installed equipment a couple of times thru the full cycle before leaving to be sure of no leaks and proper "Air Gap" performance. *For large flows use (2) units in parallel or fabricate an Air Gap with larger pipe.

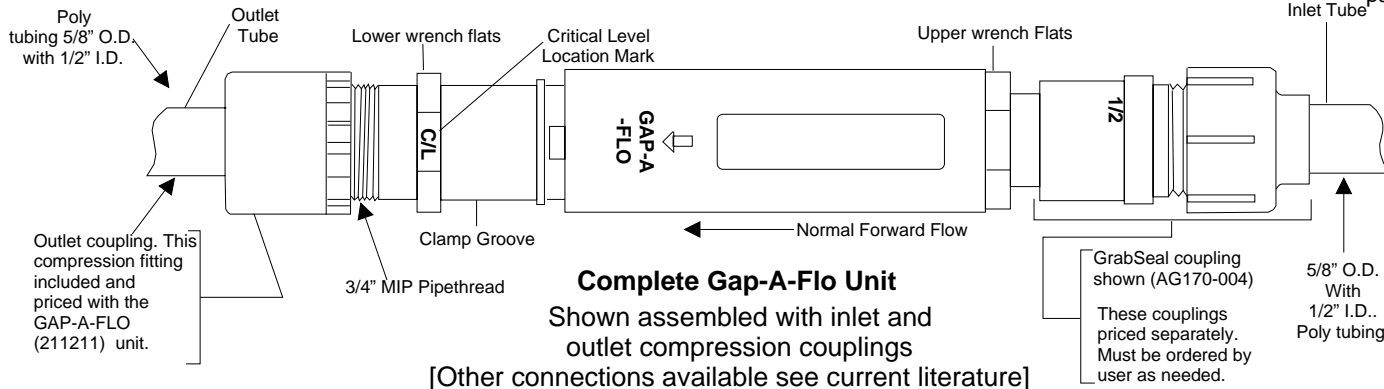

Correct Assembly – GrabSeal Compression Coupling

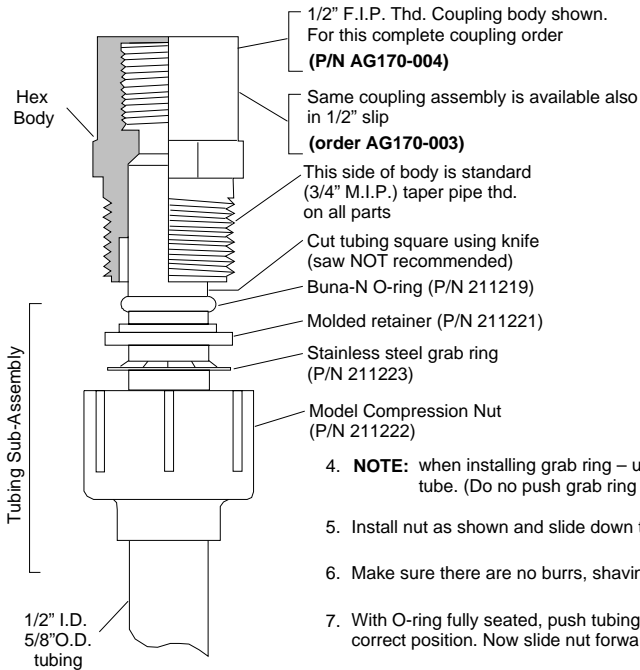

Also available complete with 1/2" barb insert body as pictured below order (P/N AG170-006)

NOTES:

- See current Air Gap International price sheet for prices and details of complete GrabSeal Coupling and/or available replacement parts. (Not all parts are available as replacement.)
- Use only the grab ring furnished by us with these coupling. Use of any other grab ring is not recommended.

ASSEMBLY INSTRUCTIONS:

1. Correct orientation of parts is shown at left. Use only original or spare parts furnished by us with these couplings.
2. When tightening nut, usually firm hand pressure is all that is required (pipe wrenches or pliers not recommended)
3. Do not bend or distort the stainless grab ring when installing.
4. **NOTE:** when installing grab ring – use the plastic retainer oriented as shown to insert the grab ring over end of tube and then to push grab ring down tube. (Do not push grab ring too far down tube – only about 3/8" to 1/2" down tube.)
5. Install nut as shown and slide down tubing. Next install grab ring, along with plastic retainer and finally the O-ring onto the 5/8" O.D. tubing.
6. Make sure there are no burrs, shaving or debris in the O-ring socket. Wetting O-ring and socket will help to fully seat the O-ring in socket.
7. With O-ring fully seated, push tubing fully forward into its socket. This will then cause retainer and grab ring to slide down tube and into their correct position. Now slide nut forward and tighten.

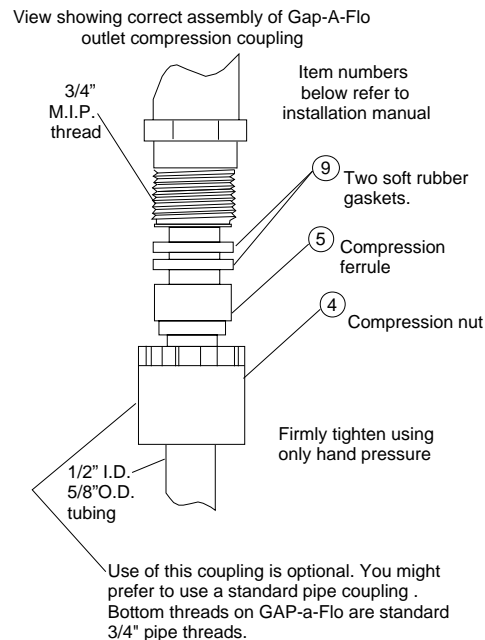
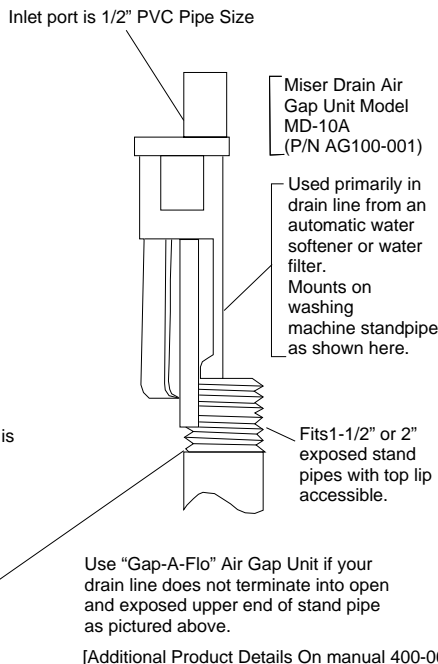
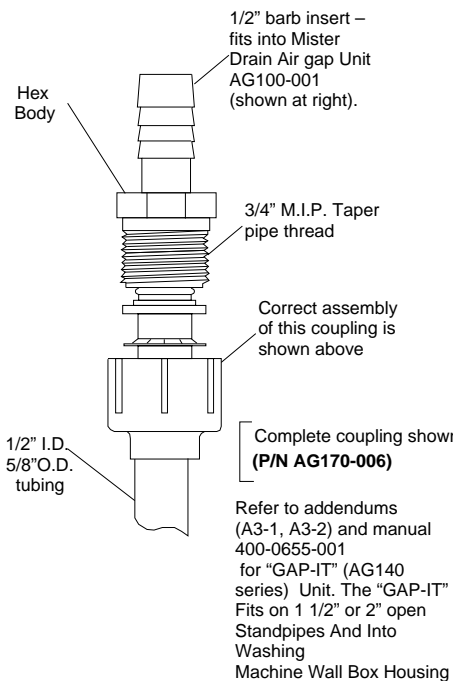

The airgap unit(s) on this sheet and including also all Altinex dishwasher airgaps are to be installed specifically only on top of drainage standpipes or in drain line piping. These models are never to be installed within or directly connected to potable water piping and never directly attach potable water, water conditioning equipment. Also every model must be installed so as to completely drain due only to gravity flow within a few seconds.

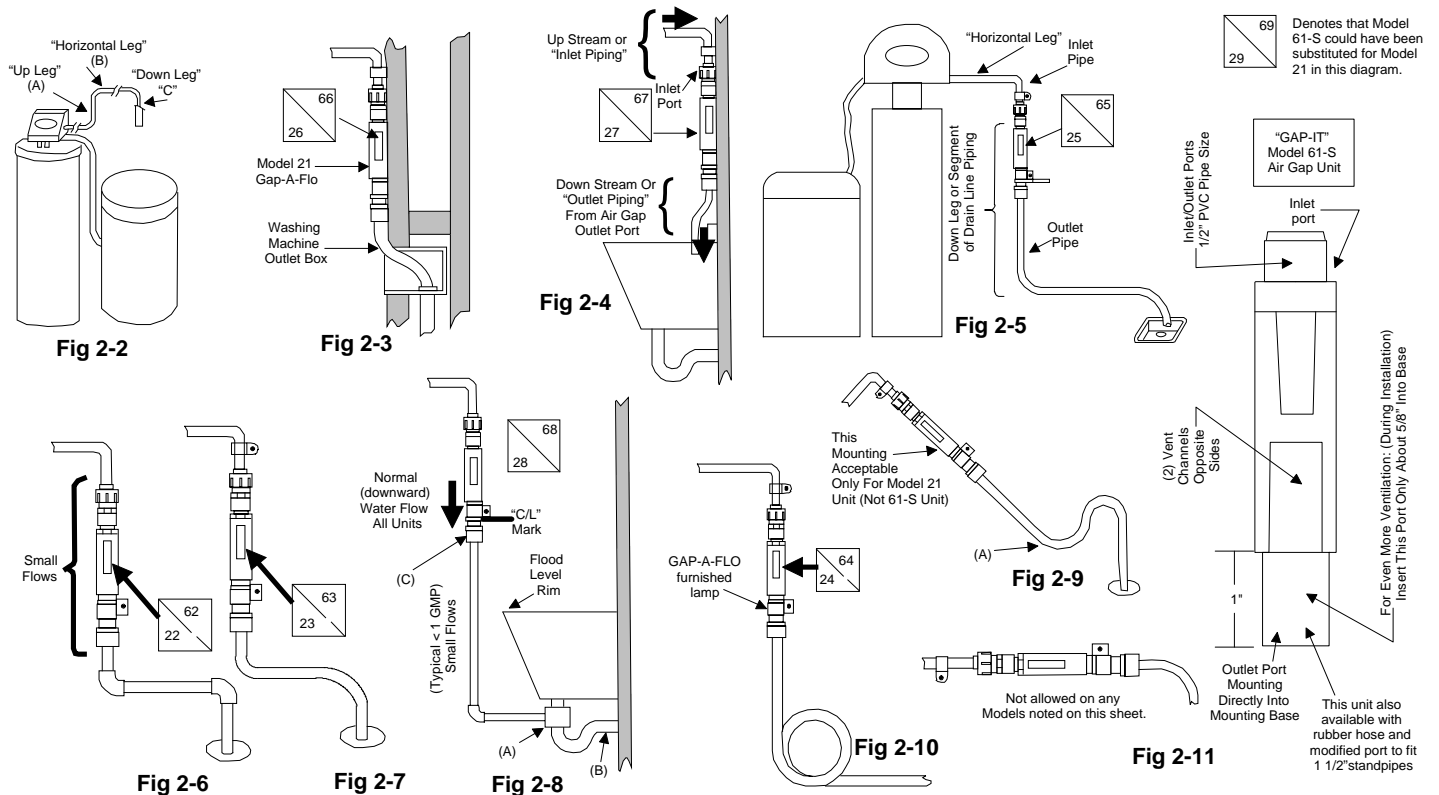

The figures above represent many of the installation situations typically encountered by the water conditioning equipment installer. These figures together with the following expectations are intended primarily to acquaint the first time customer and/or installer with the proper use and installation of these "AIR GAP" units. If you are having problems with our product functioning properly or have other questions, then contact your supplier and/or installer or the factory. Additional technical information is available by ordering "GAP-A-FLO", Installation and Service Manual (P/N 2110113), or other pertinent data.

Do the Following when installing model 21, 31, 61 AIR GAP Units:

1. Read all instructions carefully before starting the installation if you are not familiar with our AIR GAP Products.
2. Comply with all local plumbing codes.
3. Properly secure unit as well as the inlet and outlet piping. Be sure to cycle the upstream equipment thoroughly to confirm no system leaks and proper Air Gap unit performance before leaving the installation site.
- (*)4. When tightening "GAP-A-FLO" threads: use the upper wrench flats to hold the units while making the inlet connection. Similarly, use the low wrench flats while making the outlet connection.
5. At all times fluid must be able to flow freely through the Air Gap unit and the attached outlet (downstream) piping. Therefore the outlet piping should be kept as short as possible (generally 2 or 3 feet or less) and as free flowing as possible.
- (*) (For water softeners and filters (large flows) always use the supplied 5/8" O.D. outlet compression fitting – or if you prefer, the 3/4" MIP outlet thread. The 3/8" FIP outlet thread is intended only for very small flows such as from an "RO" unit.)
6. Always install our unit upstream of a trap. These Air Gap units provide only an Air Gap and not a trap.
7. Generally: Outlet pipe size and length is determined by this unit. Inlet pipe size, length and height is determined by the installation site and the water conditioner manufacturer recommendations. (Also see item 7 below.)
8. Install Model 21 vertically (Fig. 4) or at 45° (Fig. 8) or at some angle between 45° and vertical – always with the inlet elevated above the outlet port. (All model 31-S, 31-TT and 61-S must be installed vertically.)
9. Install all units in the "down leg" of the drain line piping. (Typically Figs. 2 thru 9 or Fig. 1, C above.)
10. If making a direct connection as in Fig. 7, then be sure that the AIR GAP unit is properly mounted and secured. The "C/L" mark must be elevated one inch or more above the maximum possible backflow water flood level.
11. Ref. Figs. 2, 3 – Note in all cases a trap is down stream of our unit. NOTE also in these situations that the outlet piping is short, has no elbows and presents to our unit a rapid decrease in elevation thus proving good/quick drainage through the outlet piping. Generally this represents an ideal situation. (Typical for large flows.)
12. Always use Teflon tape on all molded plastic threads and use extra caution so as not to over tighten or damage the threads, particularly female threads. Use caution when connecting to barb fitting ports of model 31 and 61-S units

DON'T do the following when installing model 21, 31, 61 Air Gap units:

1. Never install in the "up leg" (Fig. 1 point A) or horizontal leg (Fig. 1, point B or Fig. 10) of the drain line piping.
2. Never install such that the inlet port is less than 45° above the outlet port (Fig. 8 depicts 45° mounting)
3. Avoid long horizontal piping in the outlet piping (Fig.4 or Fig. 5); minimizing elbows in outlet piping (Fig.5); avoid any severe turns or elevation of outlet piping such as Figs. 6, 8 or 9. (Water flow in outlet piping should not be restricted by severe turns or elevation increase, (2-8) particularly if large flows are involved as from a softener.)
4. Generally, never make a hard connection or direct connection between our unit and the house drain/waste piping. NOTE: no direct connections in Figs. 2, 3, 4, 5, 6, 8. Note that there is a direct connection Fig. 7 at point (A). This is OK for smaller flows (generally less than 1 GMP) as from "RO" units, so long as unit "C/L" (after mounting unit) is above the sink top rim (flood level) and/or above the maximum possible "back flow" water flood level (spill level).
5. Never connect downstream of a trap (Fig. 7, Point B) unless a new trap is provided in the new piping line between the connections at locations (C) and (B).
6. Do not use the small flat injector washer (item 7 of #2110113) for water softener or filter installations; only use for small flows such as small "RO" units or systems.
7. Outlet piping should never be smaller than inlet piping and must be installed so as to easily handle the maximum fluid flowing thru the Air Gap unit. When inlet flow stops, the installation should allow unit to drain freely and completely within 5 seconds. Don't install units where they will be subject to freezing or severe weather.